



Reg. No. :

--	--	--	--	--	--	--	--	--	--	--	--	--	--	--	--	--	--	--	--

**Question Paper Code : 91663**

B.E./B.Tech. DEGREE EXAMINATIONS, NOVEMBER/DECEMBER 2019

Second Semester

Civil Engineering

GE 6253 – ENGINEERING MECHANICS

(Common to All Branches)

(Regulations 2013)

Time : Three Hours

Maximum : 100 Marks

Answer ALL questions.

PART – A

(10×2=20 Marks)

1. A vector  $\vec{F}$  starts at point (2, -1, 2) and passes through the point (-1, 3, 5). Find its unit vector.
2. State the principle of transmissibility.
3. Give the different types of support in beams.
4. State Varignon's theorem.
5. Define 'centroid of a plane area'.
6. What do you understand by mass moment of inertia ?
7. A train running at 80 km/h is brought to a standing halt after 50 seconds. Find the retardation.
8. What is dynamic equilibrium ?
9. What is dry friction ?
10. What is general plane motion ? Give one example.



## PART - B

(5×16=80 Marks)

11. a) A horizontal line PQRS is 12 m long, where  $PQ = QR = RS = 4\text{ m}$ . Forces of 1000 N, 1500 N, 1000 N and 500 N act at P, Q, R, S respectively in downward direction. The line of action of these forces makes angle of  $90^\circ$ ,  $60^\circ$ ,  $45^\circ$  and  $30^\circ$  respectively with PS. Find the magnitude, direction and position of resultant force. (16)

(OR)

- b) A light string ABCDE whose extremity A is fixed, has weights  $W_1$  and  $W_2$  attached to it at B and C. It passes round a small smooth peg at D carrying a weight of 300 N at the free end E as shown Fig. 11 b. If in the equilibrium position, BC is horizontal and AB and CD make  $150^\circ$  and  $120^\circ$  with BC, find (i) Tensions in the portion AB, BC and CD of the string and (ii) Magnitudes of  $W_1$  and  $W_2$ . (16)

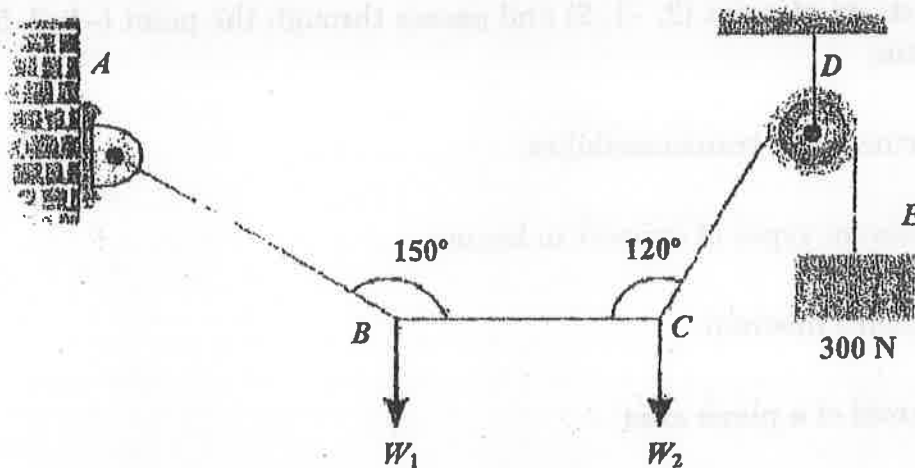

Fig. 11(b)

12. a) A roller of radius 30 cm weighs 2.5 kN. It is to be pulled over a rectangular obstruction of height 10 cm by a horizontal force  $F$  passing through the centre of the roller. Find the magnitude, if the force  $F$  required just to turn the roller over the corner of the obstruction. Also find the magnitude and direction of the minimum force required for the same. (16)

(OR)



- b) i) A body of mass 900 kg is suspended by two cables PR and PQ making an angle of  $40^\circ$  and  $50^\circ$  respectively with the ceiling. Find the tension in the cables PQ and PR. (8)
- ii) A father and his son carry a block of mass 50 kg by using a uniform bar of length 3 m and mass 16 kg. The son can bear only half the load carried by the father. Find the location of the block on the bar. (8)

13. a) Determine the location of centroid for the right angle triangle from the first principles and find the volume of cone using Pappus-Guldinus theorem. (16)

(OR)

b) Calculate the moment of inertia of the section shown in Fig. 13(b) about "x" and "y" axes through the centroid. (16)

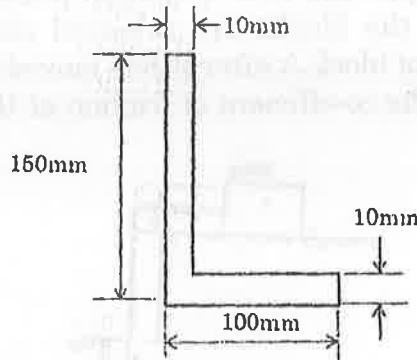

Fig. 13(b)

14. a) Two stones A and B are projected from the same point at inclinations of  $45^\circ$  and  $30^\circ$  respectively to the horizontal. Find the ratio of the velocities of projection of A and B if the maximum height reached by them is the same. (16)

(OR)

b) A block and pulley system is shown in fig. 14(b). The coefficient of kinetic friction between the block and the plane is 0.25. The pulley is frictionless. Find the acceleration of the blocks and the tension in the string when the system is just released. Also find the time required for 100 kg block to come down by 2 m. (16)

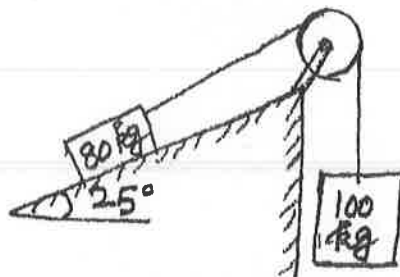

Fig. 14(b)



15. a) The two blocks of mass 20 kg and 40 kg are connected by a rope passing over a friction less pulley as shown in Fig. 15(a). Assuming co-efficient of friction as 0.3 for all contact surfaces. Find the tension in the string, acceleration of the system. Also compute the velocity of the system after 4 second starting from the rest. (16)

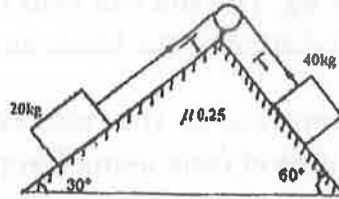

Fig. 15(a)

(OR)

- b) An inextensible string passing over a smooth pulley as shown in Fig. 15(b) joining two blocks. If the blocks are released simultaneously from rest, determine the velocity of block A after it has moved over 2 m and the tension in the string. Assume the co-efficient of friction at the contact surface is 0.2. Use energy principle. (16)

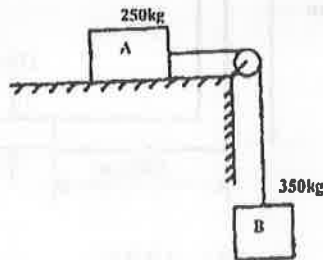

Fig. 15(b)